

## The measurement of oxygen consumption and ventilation volume of draught animals using a modified Oxylog<sup>1</sup>

Peter R. Lawrence<sup>2,\*</sup>, Jeroen T. Dijkman<sup>3</sup>

*Centre for Tropical Veterinary Medicine, University of Edinburgh, Easter Bush, Roslin, Midlothian, EH25 9RG, Scotland, UK*

Received 12 May 1997; accepted 30 May 1997

---

### Abstract

This paper describes how the Oxylog, an apparatus for measuring the respiratory ventilation volume and oxygen consumption of ambulatory human beings which is manufactured by Morgan, Kent, UK has been adapted for use with draught animals up to 500 kg live weight. Modifications included a suitable face mask which can be made cheaply and easily for animals of different sizes and two types of enlarged flow meters allowing ventilation volume (VV) up to 320 l min<sup>-1</sup> and oxygen consumption (VO<sub>2</sub>) up to 13 l min<sup>-1</sup> to be measured. When tested against a calibrated piston pump, the modified Oxylog performed as well as the original and measured VV and VO<sub>2</sub> to ±1%. Determinations of VO<sub>2</sub> of a cow agreed to within ±6% with simultaneous measurements obtained from an open circuit, laboratory based respirometric system (average difference 1.5% SD ±3.6, *n* = 14). Examples are given of results obtained from animals working in the field in Nigeria and Nepal. © 1998 Elsevier Science B.V.

*Keywords:* Draught animals; Energy expenditure; Oxygen consumption; Oxylog

---

### 1. Introduction

Most measurements of the energy expenditure of working animals to date have been made under laboratory conditions while the animals carried out standard work tests. There is, however, a need for reliable

methods which can be used in the field to assess the energetic efficiency of animals working under different conditions and to quantify their energy expenditure in relation to food energy intake.

All actual and potential methods have been reviewed by Lawrence, Pearson and Dijkman [1] who concluded that, for short term measurements from a few minutes to several hours, the only feasible methods currently available were those in which energy expenditure was derived from measurements of oxygen consumption using 'breath-by-breath' analysis.

All reported apparatuses require the animal under investigation to wear an airtight face mask. The apparatus described by Clar [2] measures the total air flow with a mechanical gas meter attached to the outlet of

---

\*Corresponding author. Fax: 00 49 711 459 3702; e-mail: lawrence@uni-hohenheim.de

<sup>1</sup>Presented at the Twelfth Ulm-Freiberg Conference, Freiberg, Germany, 19–21 March 1997

<sup>2</sup>Present address: Institute for Animal Production in the Tropics and Subtropics, University of Hohenheim (480), D-70593 Stuttgart, Germany.

<sup>3</sup>Present address: Food and Agriculture Organisation of the United Nations (FAO), Animal Production and Health Division, Room C-561, Viale delle Terme di Caracalla, 00100 Roma, Italy.

the mask. A proportional sample of the expired air is collected in a plastic bag for later analysis in the laboratory. This apparatus has the advantage that it is possible to measure all components of the gaseous exchange of an animal, i.e. oxygen consumption, CO<sub>2</sub> production and, in ruminants, methane production but suffers from the disadvantage that these values can be measured only over a fixed period, i.e. they cannot be continuously recorded.

Howell and O’Niell [3] describe a device in which total expired air flow is measured by a heated pneumotachograph. A sample of this airflow is then passed over a polarographic oxygen electrode in a small reservoir designed to even out the oxygen concentration over several breaths so that the electrode (response time 90% in 300 ms) can monitor any changes accurately. Processing of the signals from the flow meter and polarographic electrode is done by a microprocessor based data logger which forms part of the portable apparatus. Total airflow and oxygen consumption are subsequently calculated by computer after the data have been off-loaded.

In both these apparatuses, the flow meter is mounted on the outlet side of the mask. Condensation of water from the expired air can cause corrosion in mechanical gas meters and decreases the precision of most other types. Both apparatuses use face masks which require a lot of time and money to construct. Neither is commercially available.

For studies in several parts of the world, the present authors therefore decided to adapt an apparatus originally designed for human beings [4], the ‘Oxylog’, which had proved reliable in long-term field trials, was accurate when compared with standard laboratory methods [5] and which was commercially available.

## 2. Materials and methods

### 2.1. Description of the apparatus

The Oxylog was originally designed for humans by Humphrey and Wolff who have described it in detail [4]. It is manufactured by Morgan, Chatham, Kent UK. Fig. 1 shows the layout of the major components after adaptation for use with oxen. Air is drawn in through a turbine flow meter mounted on the inlet side of the face mask. This configuration avoids problems

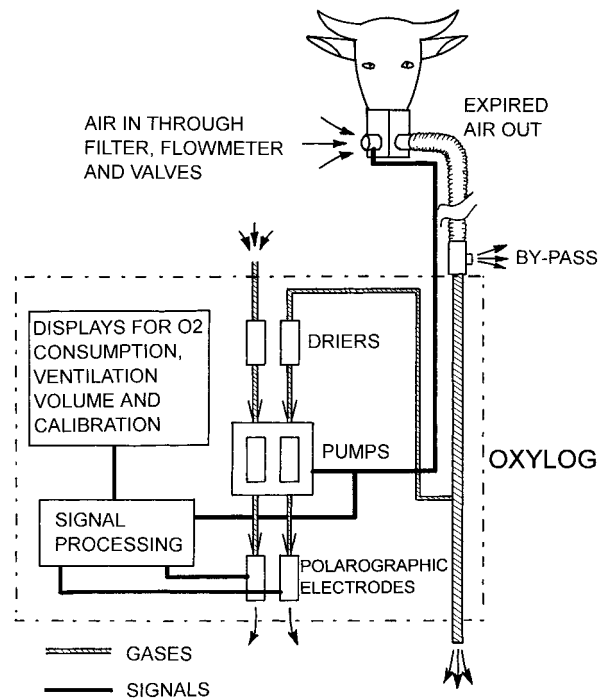

Fig. 1. Layout of the major components of the modified Oxylog.

caused by condensation of water vapour, and the use of the inlet volume to calculate oxygen consumption partly corrects for the errors that arise when the values derived are subsequently used to calculate energy expenditure using an assumed RQ value [6]. Expired air passes out of the face mask through an outlet valve and at the end of each breath a pump takes a sample at the same time as a sample of fresh air. Both samples are passed through separate tubes containing a drying agent and then over a pair of matched polarographic electrodes which measure the difference in oxygen concentration in the two air streams. The current oxygen difference is multiplied by the volume of each breath and the results summed to give the total oxygen consumption. Among other parameters, the Oxylog displays cumulative and minute ventilation volumes and cumulative and minute oxygen consumption, all in standard litres. It also shows the partial pressure of oxygen in the inspired and expired air and the difference between them ( $\Delta\text{PO}_2$ ) in mm Hg. When calculating these parameters, account is taken of the atmospheric pressure and temperature of the air stream and the inspired air is assumed to have a

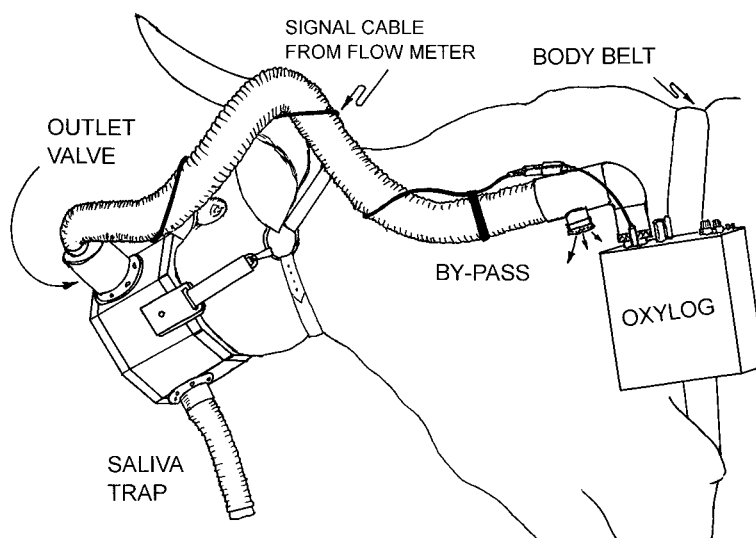

Fig. 2. Attachment of the Oxylog to a draught animal. The inlet filter, inlet valve and flow meter assembly are on the opposite side of the face mask. The Oxylog itself is counterbalanced with a weight on the opposite side of the animal.

relative humidity of 50%. The device is portable, has dimensions of  $19 \times 8 \times 22$  cm and weighs 2.6 kg, including its batteries which can work for  $> 12$  h without prior recharging. When used in the field with draught animals, the Oxylog was attached to a belt fitted with a counterweight to stop it sliding round the animal's body (Fig. 2).

## 2.2. Modifications

Three main modifications were necessary so that the Oxylog could be used for draught oxen:-

1. A face mask was designed that was quick and cheap to make, so that masks could easily be made to fit all animals.
2. The capacity of the inlet and outlet valves was increased to allow for the extra air flow and a bypass constructed so that only a portion of the increased volume of expired air passed into the sampling tube in the Oxylog.
3. Two types of modified flow meter were made to increase the maximum measurable flow three-to-fourfold from 80 l/min to 320 l/min. This meant that the ventilation volume of moderately active oxen of live weights up to 500 kg could be measured.

In addition, an auxiliary display LCD display was constructed and attached to the data output socket of the Oxylog by a 2 m long cable because the small LED displays of the Oxylog proved difficult to read especially when the instrument was attached to a moving animal in bright, tropical sunshine [7].

The basic frame of the mask was made from seven pieces of marine-quality 10 mm plywood (Fig. 3). Using this design, masks could be made to fit any shape of muzzle without altering the angles at which the wood was cut. After gluing, the mask frame was painted with an impermeable quick-drying paint (Hammerite).

The front and rear of the mask were sealed with a sheet of 1 mm thick black natural rubber (4D rubber company, Derby UK). When masks were made for oxen that had to be led by a nose ring, the front sheet was cone-shaped (Fig. 4) to allow a rod to pass from the nose ring to the outside of the mask. Where joints had to be made between sheets of rubber, the two halves of the joint were first 'immobilised' by sticking the rubber to a flat, rigid surface with double-sided adhesive tape. The exposed edges of the rubber were then coated with an appropriate contact adhesive (Bostik 3851) and stuck together. After the united rubber sheets had been removed from the flat surface and the double-sided adhesive tape peeled off, the

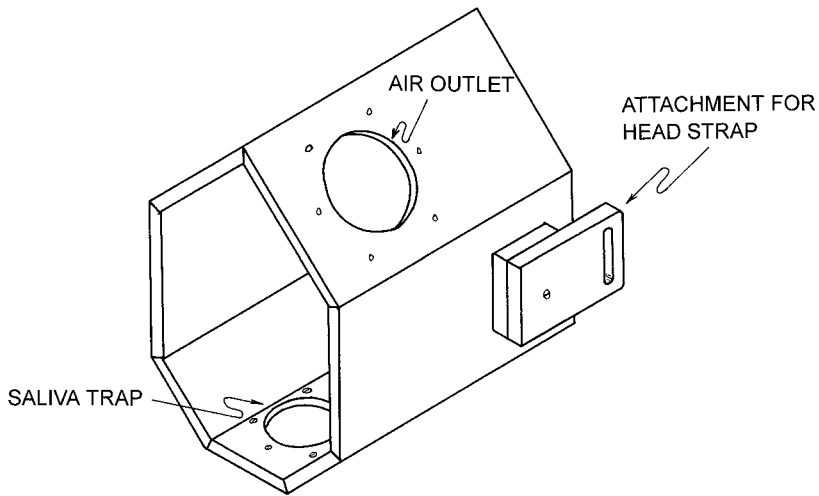
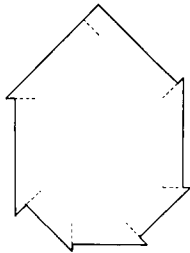

Fig. 3. The basic frame of the face mask. It is made of 10 mm thick plywood and sealed with a marine grade paint.

**FRONT COVERS OF FACE MASK**

(ALL PARTS MADE OF 1mm NATURAL RUBBER)



PLAIN COVER

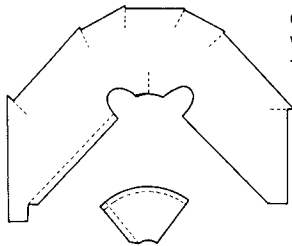

COVER FOR ANIMALS WHICH ARE LED BY THE NOSE

**REAR COVER OF FACE MASK**

(ALL PARTS MADE OF 1mm NATURAL RUBBER)

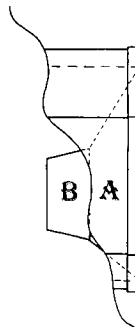
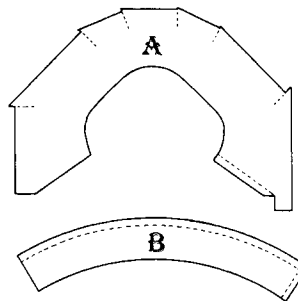

ASSEMBLED CUFF MOUNTED ON FACE MASK

Fig. 4. Front cover and rear, air tight cuff for face mask. All components are made of 1 mm thick, black natural rubber. Joints are made with a suitable rubber adhesive.

joint took up its natural shape. Provided the surfaces were prepared and the glue used in accordance with the manufacturers' recommendations, the joints produced by this method were flexible and very strong.

Formed rubber sheets were attached to the mask at the front and rear using an acrylic adhesive (Super-glue) and the joint sealed with PVC insulating tape.

The rear of the mask was fitted with an annular cuff (Fig. 4) which was designed to make an airtight seal just behind the muzzle when the mask was pushed onto the animal's nose. This arrangement was found to give a much better seal than the cuffs of foam rubber as used by Howell and O'Niell [3] and was far easier to make and use than the inflatable cuffs used by Clar. [2]

Masks used for oxen and buffalo were fitted with a saliva trap on the front of the lower panel consisting of a 150 mm length of 30 mm diameter flexible tube fitted with a rubber bung.

Inlet and outlet valve assemblies were fitted to the upper surfaces of the mask using  $6 \times 5$  mm screws and nuts and could easily be transferred from one mask to another.

As much empty space as possible inside the mask was filled with shaped pieces of expanded polystyrene to minimise dead space.

Inlet and outlet valves in the original Oxylog consisted of one 25-mm diameter 'Martindale' valve. In

the modified version, three of these valves were mounted in a pyramid shape or in later versions in a flat plate made of acrylic plastic (Perspex) (Fig. 5). The bypass consisted of a 30-mm diameter polypropylene 'T' piece as used in waste water systems. One arm of the T piece was attached via a flexible hose to the outlet from the face mask, the second to the sampling tube of the Oxylog and the third was covered by a 10 mm thick permeable foam rubber pad. This arrangement ensured that expired air filled the sampling tube in the Oxylog while at the same time any excess air could escape through the foam rubber pad without any build-up of pressure in the face mask.

The original Oxylog has a turbine flow meter (Fig. 6) which consists of a cylinder of 2.6 mm diameter and 3.0 mm length, fitted with a stationary impeller at the inlet side. A flat vane made of aluminised plastic 0.03 mm thick is mounted on an axial spindle which pivots on two jewel bearings. When the experimental animal breathes in, the inspired air is drawn in through a dust filter, passes the length of the flow meter and, finally, enters the mask via the inlet valves. As it enters the flow meter, the vanes of the impeller impart a spiral motion to the air which turns the turbine blade at a rate proportional to the air flow. An IR emitter and detector are housed in the wall of the flow meter cylinder. As the vane rotates, radiation

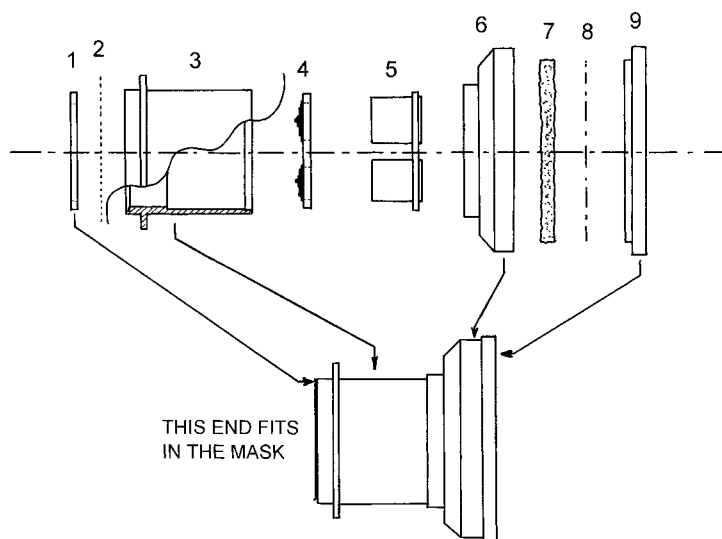

Fig. 5. Exploded view of inlet valve and flow meter assembly. Part 1 keeps part 2, a nylon mesh grid in place in part 3, the main flow meter housing. Part 4 is the valve assembly and part 5 the multiple flow meter. Parts 6 and 9 comprise the housing for the filter, part 7 which is also held in place by an aluminium grid, part 8.

## IMPELLER FLOWMETER FOR THE OXYLOG

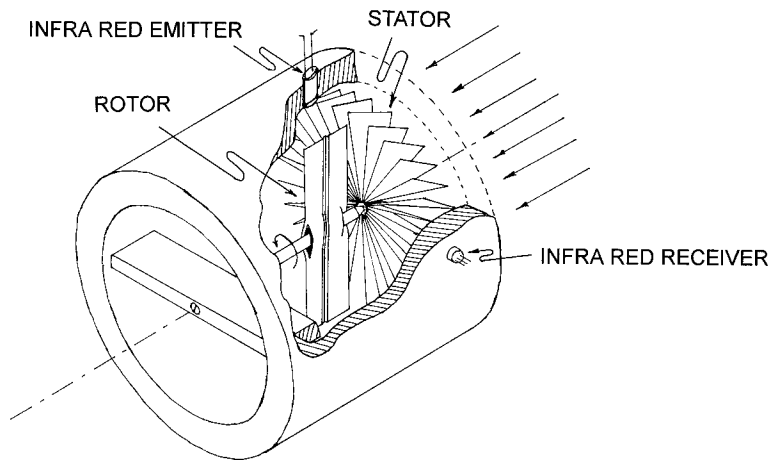

Fig. 6. Details of the original turbine flow meter.

is reflected from the emitter to the receiver twice per revolution. The signals from the receiver are then counted by the Oxylog and divided by a factor determined during calibration to give total air flow.

To accommodate larger flow rates, the capacity of the flow meter was increased by one of following two methods (Fig. 7):

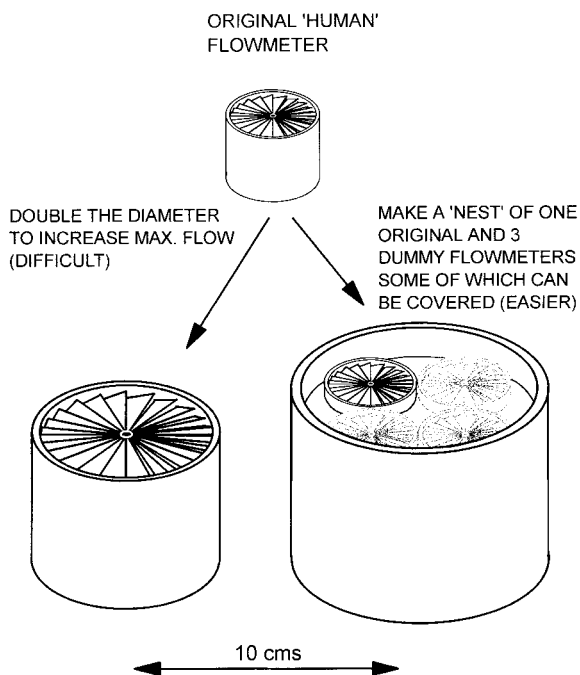

Fig. 7. Two methods for increasing the capacity of the flow meter.

(a) A scaled-up version was made of the original flow meter having a diameter twice as large and allowing maximum flow rates up to three times bigger (240 l/min). The rotor vane was also lengthened and reinforced with a longitudinal pleat 2 mm wide which despite being in the middle of the vane did not hinder the reflection of the infra red beam. Manufacture of a larger impeller assembly was a fairly difficult process and involved accurately cutting (to  $\pm 0.1$  mm) and assembling 40 separate pieces of plastic sheet. It was also difficult to ensure that the finished impeller was sufficiently rigid so that it did not flex when air was drawn in at high flow rates. If this happens, the jewel bearing in the middle of the impeller can press on the spindle and stop the vane going round. Another problem with the larger flow meter is that it is inaccurate at low flow rates, i.e. a flow meter suitable for a working animal can give inaccurate results when the animal is standing still. To overcome these problems an alternative approach was used

(b) The original flow meter was set in a plate along with three 'dummy' flow meters similar in every

way to the original one but lacking vane, spindle, bearings and IR emitters and detectors. As the incoming air passed through the flow meter and the three dummies, the maximum reading was 320 l/min, instead of 80 l/min. For experiments where it was required to measure lower flow rates, one or more of the dummy flow meters was blocked with a flat rubber plug. Thus, maximum readings could be obtained at 320, 160 or 80 l/min as required. The plate in which the flow meter and dummies were set was of 100 mm diameter and fitted easily inside the cylinder containing the dust filter and inlet valves on the inlet side of the face mask (Fig. 5)

### 2.3. Calibration of the flow meters

A hand-operated piston pump was constructed with a displacement of exactly 8.117 l and attached to the flow meter. Air was drawn through the flow meters at average rates of 20–230 l/min for the enlarged flow meter and 20–320 l/min for the multiple flow meter. The valves in the pump were arranged so that air passed through the flow meter only on the outward stroke, thus mimicking the effect of an animal breathing. The instantaneous flow rates during the outward stroke were thus twice these values. In each trial, air was pumped until the Oxylog reading was at least 100 l. The total flow of air as recorded by the Oxylog was then compared with the volume displaced by the pump after appropriate corrections had been made for the pressure, temperature and humidity of the air flow. The results for the large flow meter were expressed as a correlation between the Oxylog reading and the volume displaced by the pump and those for multiple flow meter as the ratio (Volume displaced by pump / (Oxylog reading × number of small flow meters open)) for each pair of readings.

### 2.4. Testing the ability of the modified system to measure oxygen consumption

Both sides of the Oxylog sampling system were flushed out first with nitrogen gas and then with fresh air and the device was set to zero following the manufacturer's instructions. The sample side was then flushed with a standard gas containing 17.00% oxygen (CO<sub>2</sub> 2.98%, balance nitrogen). The calibration pump

was used to pass air through the flow meter at different rates as described above. The Oxylog registered an oxygen 'consumption', the extent of which was determined by the difference in oxygen partial pressure between the standard gas and fresh air and the volume of air drawn through the flow meter by the pump. When the Oxylog showed an apparent oxygen consumption of at least 5 l, the displayed oxygen 'consumption' was compared with that calculated from the total flow from the pump and the difference in oxygen concentration between fresh air and the standard gas. The tests were performed at air flow rates similar to those used in the previous section for calibration of the flow meters and, thus, covered the full range of measurable oxygen consumption rates. The results for the large flow meter were expressed as a correlation between the Oxylog reading and the value calculated as (Volume displaced by the pump × the difference in oxygen concentration between the standard gas and fresh air) and those for multiple flow meter as the ratio ((Volume displaced by pump × the difference in oxygen concentration between the standard gas and fresh air) / (Oxylog reading × number of small flow meters open)) for each pair of readings. In both cases, appropriate corrections were made for atmospheric pressure, temperature and humidity.

### 2.5. Measuring the resistance of the valves and flow meter to air flow

In any respirometric technique which involves an airtight face mask with valves, it is essential that the valves and flow meter have a minimal effect on the air flow in and out of the lungs of the experimental subject [8]. The inlet valve and flow meter assembly of the modified Oxylog were, therefore, connected to a centrifugal pump and mass flow meter and air was drawn through at rates of 90–700 l/min. The maximum rate was greater than the maximum instantaneous flow rate in the other tests. Pressure difference across the assembly was measured with a differential water manometer.

### 2.6. Comparison of the Oxylog with a laboratory-based open circuit respiration system

This comparison was made using a four-year old cow of 350 kg live weight, trained over a period of four

months before the trials began to work with the Oxylog and the open circuit system. The Oxylog was placed in a wooden box with a permeable top made of foam rubber which the cow carried on her back. A flexible hose connected the box to the inlet of an open circuit system. In this way, all the air expired by the cow went first through the Oxylog and was then drawn through the open circuit system for further confirmatory analysis. A total of 14 paired measurements, each lasting at least 30 min, was made when the cow was standing, walking or pulling a load on a treadmill or circular race. Total oxygen consumption was calculated for both methods and ranged from 84–300 l per trial, corresponding to energy expenditure rates in the 800–2800 W range.

### 2.7. Field trials

The modified Oxylog has been used in field trials with oxen in Nepal (*Bos indicus*), bulls (*Bos indicus*, breed Bunaji) in Nigeria, [7], donkeys (*Equus asinus africanus*) in Tunisia and water buffalo (*Bubalus bubalis*) in Columbia [9]. Examples of the type of data obtained in the first two of these projects and some of the problems encountered in the field are given in the Section 3 below.

## 3. Results

### 3.1. Comparison of airflow measurements

The enlarged flow meter gave a linear response to flow over the 20–230 l/min range, when compared with the piston pump such that  $y = 0.252x + 1.176$

Table 1

Comparison of airflow measurements with (a) – the multiple flow meter + Oxylog and (b) – a manually operated piston pump of 8.117 l displacement

Number of flow meters open	Range of flow rates tested/ (l/min)	Pump volume/(volume recorded by Oxylog × number of flow meters open) ± standard deviation ( $n = 8$ for each group)
1	20–80	$0.99 \pm 0.010$
2	40–160	$0.98 \pm 0.006$
4	80–320	$1.01 \pm 0.013$
	Average	$0.994 \pm 0.015$ ( $n = 24$ )

( $n = 26$ ;  $r = 0.9996$ ) where ‘y’ is the Oxylog reading and ‘x’ the volume displaced by the pump. Both ‘y’ and ‘x’ are in standard litres.

For the multiple flow meter, the ratio (Volume displaced by pump/(Oxylog reading × number of small flow meters open)) was calculated for each pair of readings (Table 1). There were no significant differences between the average ratios calculated for the different flow meter configurations and the overall average for all flow rates was  $0.994 \pm 0.015$  (St. Dev.)

### 3.2. The ability of the modified system to measure oxygen consumption

The oxygen consumption measured by the Oxylog when it was fitted with the enlarged flow meter (y) was compared with that calculated from the displacement of the pump and the difference in oxygen concentration between the standard gas and fresh air (x). The result was expressed as a regression equation  $y = 0.230x + 0.016$  ( $n = 26$ ;  $r = 0.9998$ ). Both ‘y’ and ‘x’ are in standard litres and the range of oxygen consumption rates was 0.4 to 7 l/min.

For the multiple flow meter, the ratio (Apparent oxygen consumption by pump/(Oxylog reading × number small flow meters open)) was calculated for each pair of readings (Table 2). There were no significant differences between the average ratios calculated for the different flow meter configurations and the overall average for all flow rates was  $1.007 \pm 0.017$ .

Table 2

Comparison of apparent oxygen consumption calculated from  $\Delta PO_2$  and the displacement of a calibrated piston pump and the apparent oxygen consumption recorded by the Oxylog × number of flow meters open in the ‘multiple’ flow meter

Number of flow meters open	Range of flow rates tested/ (l/min)	Apparent oxygen consumption calculated from $\Delta PO_2$ and the pump displacement/ (Apparent oxygen consumption recorded by the Oxylog × number of flow meters open) ± standard deviation ( $n = 8$ for each group)
1	20–80	$1.00 \pm 0.018$
2	40–160	$1.01 \pm 0.016$
4	80–320	$1.01 \pm 0.015$
	Average	$1.007 \pm 0.017$ ( $n = 24$ )



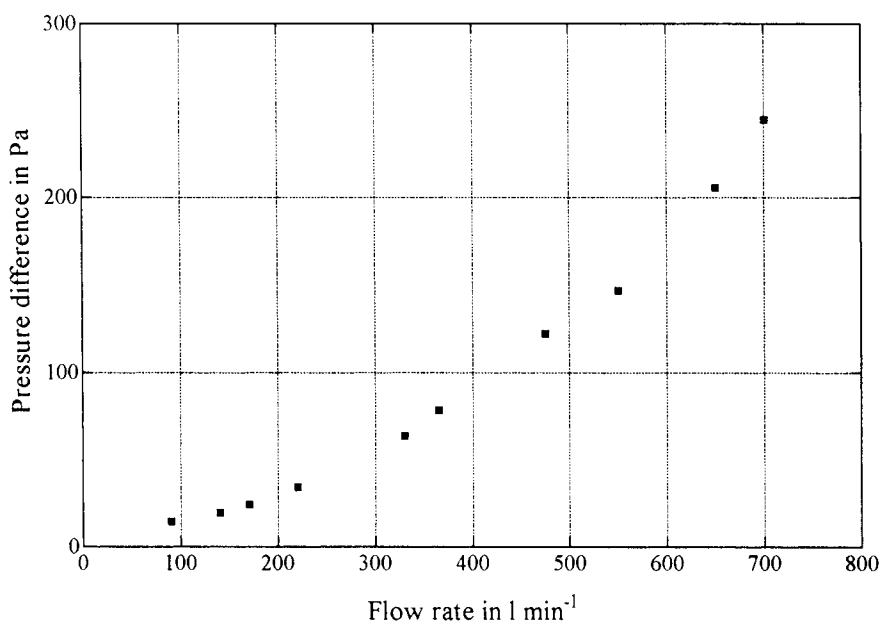

Fig. 8. Resistance to airflow of the inlet valves and flow meter.

### 3.3. The resistance of the valves and flow meter to airflow

The resistance, as measured by the pressure drop across the flow meter assembly, was low and although it increased in an exponential manner as the flow increased (Fig. 8) it was still only 20 mm of water pressure at 640 l/min which was the maximum capacity of the Oxylog flow meter. In this respect, the mask performed favourably compared with masks designed for humans [8].

### 3.4. Comparison of the Oxylog with a laboratory-based open circuit system.

The 14 paired determinations of oxygen consumption were compared using a paired 't' test. The Pearson correlation coefficient was 0.991 and was highly significant ( $P < 0.001$ ). On average, the Oxylog gave values which were 1.51% (S.D.  $\pm 3.59$ , range +5.5 to -4.6%) higher than those from the open circuit system. This difference was not statistically significant.

### 3.5. Field trials: Some results and observations

The field trial in Nepal included measurements of oxygen consumption, ventilation volume and  $\Delta PO_2$

while oxen were standing, walking on level ground, walking uphill and ploughing. Fig. 9 shows the variations in ventilation volume and  $\Delta PO_2$  recorded automatically every minute during 3.5 h when the ox was alternately pulling a plough and resting. Halfway through the experiment, the sun came out and the resultant heat stress caused the animal to pant. As a result, the ventilation volume rose and  $\Delta PO_2$  decreased. Although the oxygen consumption pattern during work and rest stayed the same (not shown on this graph), the recorded values became less precise because both of the parameters from which oxygen consumption is calculated were being measured at the extreme range of the instrument (ventilation volume at the upper limit and  $\Delta PO_2$  at the lower)

In central Nigeria [7], measurements were taken of the same parameters while oxen were walking and ploughing on different consistencies of soil. The data were used to calculate energy cost of walking ( $J m^{-1} kg\text{-live weight}^{-1}$ ) and efficiency of doing work ((work done/energy used for work)  $\times 100$ ) using the formulae of Lawrence and Stibbards [10]. Work done was measured using an ergometer [11] and the energy used for work was calculated as oxygen consumption (l)  $\times 20.7$ . The latter factor was derived using the factors of Brouwer [12] with an assumed RQ of

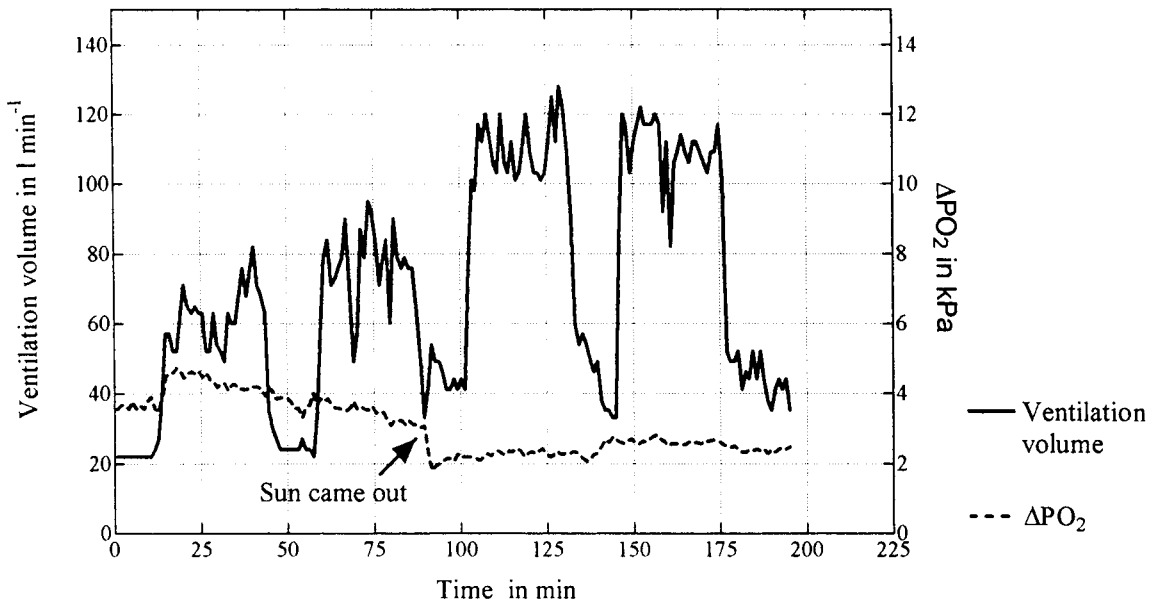

Fig. 9. Variations in ventilation volume and differences in oxygen partial pressure between inspired and expired air in an ox working and resting in Nepal.

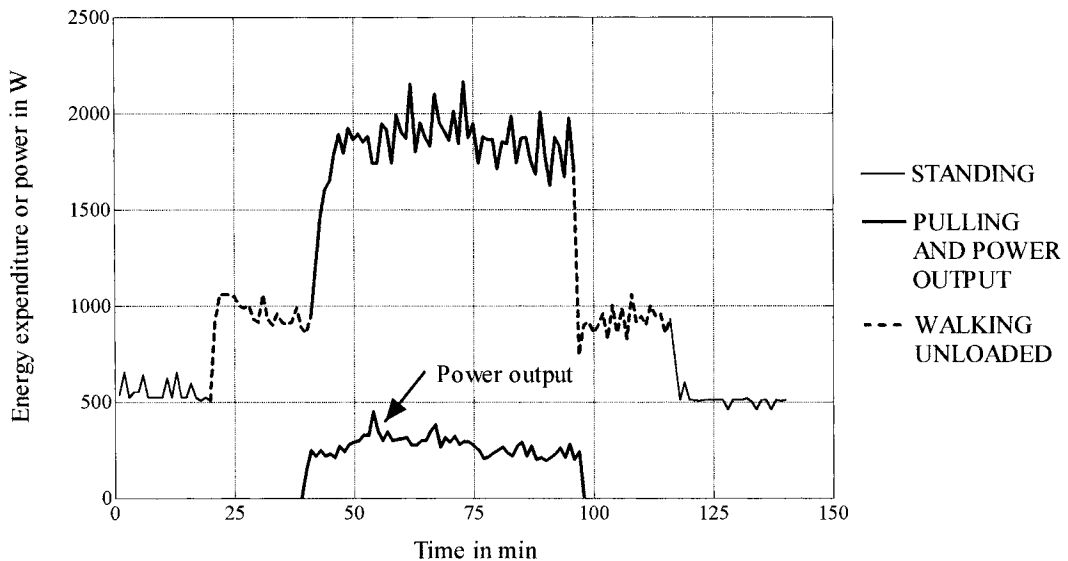

Fig. 10. Variation in energy expenditure calculated from oxygen consumption of a Bunaji bull standing, walking and working in Nigeria.

0.88. Fig. 10 shows the results of one such experiment in which values were recorded every minute.

The proportion of animals that were willing to work while wearing the modified Oxylog mask varied greatly between projects. All eight oxen used in

Nigeria accepted the mask but only half the available animals in Nepal and Columbia. Animals who reacted adversely to the mask would either try repeatedly to knock it off or stand quite still and refuse to move. Animals that accepted the mask initially, soon worked

quite normally while wearing it and showed no alterations in their normal breathing patterns.

Failure of equipment during these trials occurred only rarely and was always caused by damaged inter-connecting cables or faulty plugs. No breakdowns ever occurred within the Oxylog itself or in the adapted face mask and attachments even under the harshest tropical conditions.

#### 4. Conclusions

The modified Oxylog has proved an accurate and reliable method for the measurement of oxygen consumption of working animals in the tropics over several years. The modifications described in this paper are relatively cheap and easy to carry out. This is especially true in the case of the face mask frame which can be constructed in a few hours from materials costing less than £5.00. This means that masks can easily be made to fit animals differing in size and shape unlike other masks described in the literature.

In 'bench' tests, the ability of the modified Oxylog to measure total airflow and oxygen consumption was as good as that of the original instrument. Total flow from a piston pump and apparent oxygen consumption (calculated as the product of the pump displacement and the difference in oxygen concentration between fresh air and a standard gas) both agreed to within  $\pm 1\%$  with the values given by the Oxylog. Both types of modified flow meter worked well, but the 'multiple' flow meter was easier to make and extended the useful range of the instrument further. Also, there is no reason, apart from considerations of space why the multiple flow meter idea should not be extended further to include four or more dummy flow meters whereas the mechanical fragility and inertia of the rotor vane in the enlarged flow meter precluded the enlargement of this design any further.

When the ability of the modified Oxylog to measure the oxygen consumption of a cow was compared with simultaneous measurements made with an open circuit system, the two methods agreed within  $\pm 6\%$ . This level of agreement is similar to that found by other

workers when the oxygen consumption of human subjects was tested with the 'human' version of the Oxylog and compared with that from a Douglas bag method [5,13].

The use of the Oxylog in the field posed a few problems. The acceptance rate of the mask by experimental animals varied from 50–100% and seemed to depend on the breed of animal rather than any other factor. All animals that accepted the mask initially were, after only a few training sessions, able to wear it for prolonged periods without apparent discomfort. The mask had no apparent effects on the animals' breathing pattern and the resistance of the modified valves and flow meters to respiratory airflow was minimal.

#### References

- [1] P.R. Lawrence, R.A. Pearson, J.T. Dijkman, in: *Isotope and Related Techniques in Animal Production and Health*, International Atomic Energy Agency, Vienna, 1991, p. 211.
- [2] U. Clar, *Entwicklung einer Feldmethode zur Messung des Energie Umsatzes bei Zugtieren*, Ph.D. Thesis, University of Hohenheim, 1991.
- [3] P.J. Howell, D.H. O'Niell, ILCA contract report Document OD/90/05, AFRC Engineering Overseas Division, Silsoe, UK, 1990.
- [4] S.J.E. Humphrey, H.S. Wolff, *J. Physiology (London)* 267 (1977) 12.
- [5] M.H. Harrison, G.A. Brown, A.J. Belyavin, *Ergonomics* 25 (1982) 809.
- [6] J.B. deV Weir, *J. Physiology (London)* 109 (1949) 1.
- [7] J.T. Dijkman, P.R. Lawrence, *J. Agricultural Science (Cambridge)* 128 (1997) 95.
- [8] J.A. Hirsch, B. Bishop, *J. Appl. Physiology: Respiratory Environmental and Exercise Physiology* 53(5) (1982) 1281.
- [9] J.T. Dijkman, *The Measurement of Draught Ruminant Energy Expenditure in the Field*, Ph.D. Thesis, University of Edinburgh, 1993.
- [10] P.R. Lawrence, R.J. Stibbards, *Animal Production* 50 (1990) 29.
- [11] P.R. Lawrence, R.A. Pearson, *J. Agricultural Science (Cambridge)* 105 (1985) 703.
- [12] E. Brouwer, in: K. Blaxter (Ed.), *Proceedings of the Third Symposium on the Energy Metabolism of Farm Animals*. EAAP Publications No. 11, Academic Press, London, 1965, p. 441.
- [13] G. McNiell, M.D. Cox, J.P.W. Rivers, *Amer. J. Clinical Nutrition* 45 (1987) 1415.